

Installation, Operation and Maintenance Manual

ScaleStop Residential Systems
Chemical Free, Salt Free Scale Prevention



NSS-744R
NSS-844R
NSS-948R
NSS-1054R
NSS-1252R

6586 Hypoluxo Road, Suite 362
Lake Worth, FL 33467

(800) 783-0310

email: info@nextfiltration.com

web: www.nextfiltration.com

© 2006-2010 next filtration technologies inc.

Table of Contents

Introduction.....	3
System Overview.....	4
System Specifications	5
Cautions	6
Notes to the Installer.....	6
Installation and Start-Up.....	7
Note to the Homeowner.....	8
Warranty	9 & 10

Introduction

The next-ScaleStop system provides protection from scale formation throughout the home. The ScaleStop system can be installed at the point of entry to treat your entire home, both hot and cold water, or it can be located directly before a water heater or other device (e.g. sauna, etc) that requires protection from hard water.

ScaleStop reduces or eliminates scale formation on internal and external plumbing surfaces as well as reducing spotting and streaking normally associated with hard water.

ScaleStop prevents scale by transforming the normal dissolved hardness minerals into undissolved crystal micro-particles. These crystals stay suspended in the water and have a greatly reduced ability to react and attach to surfaces like dissolved hardness does. Therefore the problem of internal build-up of scale in pipes, water heaters and on fixtures and glass is greatly reduced.

ScaleStop is not a water softener – Low or phosphate-free cleaning products are recommended to achieve optimum results. Modern surfactant or detergent based, liquid soaps are preferred over old-fashioned caustic solid soaps.

Unlike softened water, Scalestop treated water maintains the beneficial essential mineral content of your water and is safe to drink.

ScaleStop Benefits.

- Chemical Free Scale Prevention. Cost savings and environmental benefits.
- Virtually Maintenance Free. No salt bags or other chemicals to buy, transport and store.
- No Electricity, no wastewater, completely self-contained.
- Beneficial minerals retained for more healthful drinking water.
- Improves the efficiency of water-using appliances.
- Simple installation – no electrical and drain hookup
- Safe for landscaping and lawn watering. No need to costly bypass plumbing
- Compatible with all on-site and community wastewater treatment systems
- Not subject to water softener restrictions and “bans”

System Overview

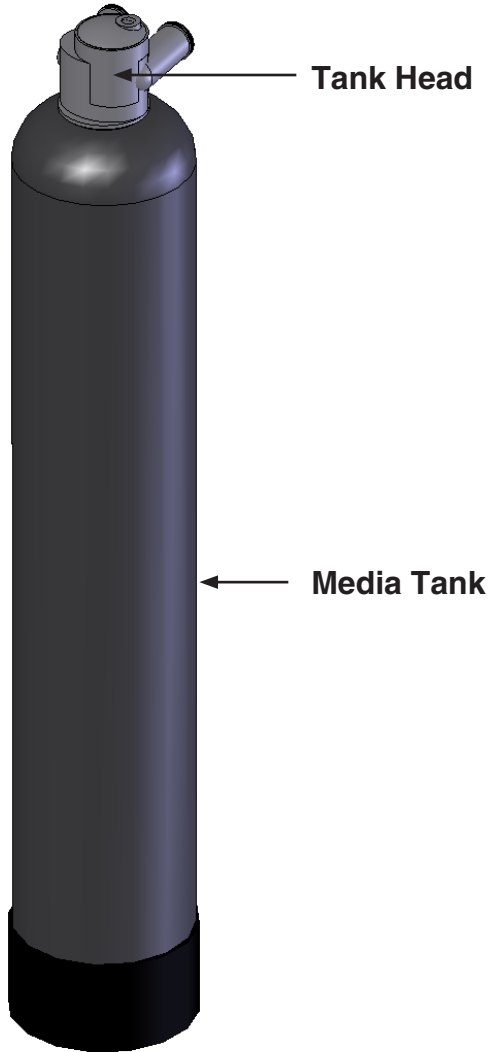

Typical Connection Fittings

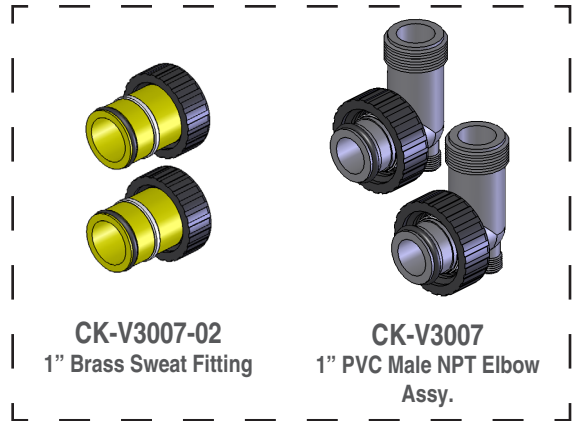

Optional Connection Fittings

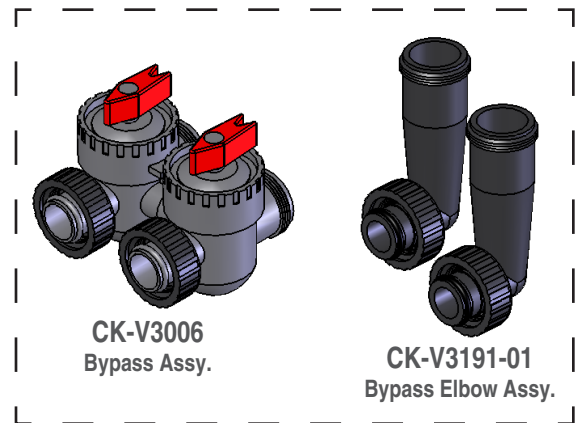

Equipment Specifications

next-ScaleStop systems are complete, self-contained, loaded with media and ready to use. A simple inlet and outlet connection is all that is required for installation. Please review operating pressures, temperatures and water chemistry limitations to ensure compatibility.

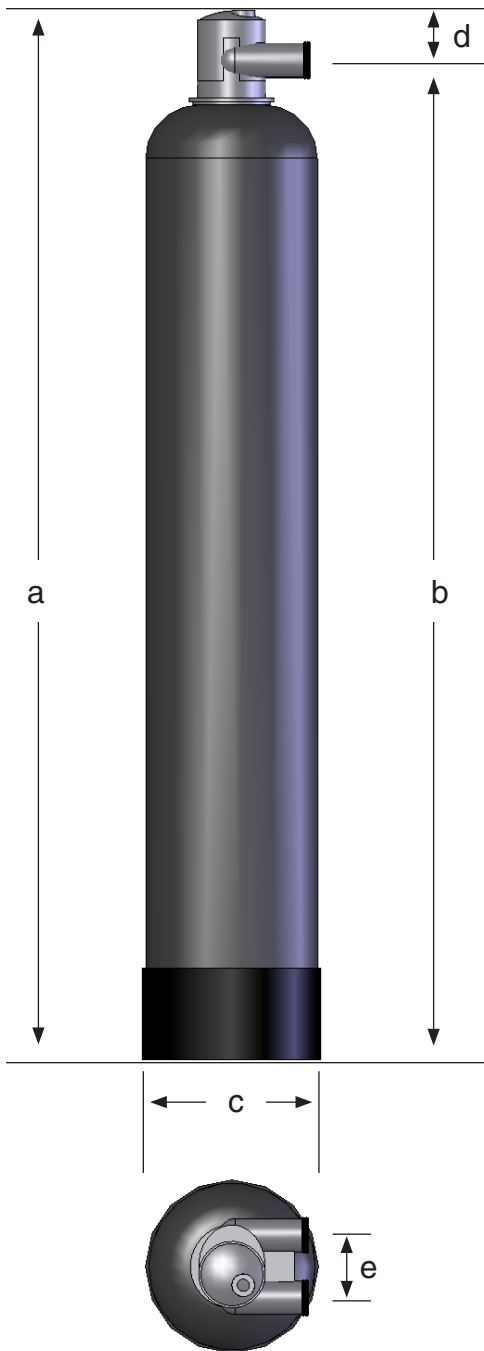

Specifications

Inlet/Outlet Connection	3/4" - 1.25" (multiple options)
Temperature	40° - 110°F
pH	6.5 to 8.5
Ferrous Iron, Max*	0.3 mg/L
Manganese, Max*	0.05 mg/L
Copper, Max*	1.3 mg/L
Water Pressure	15 min., 100 max (PSI)

* See note about Iron, Manganese and Copper on the next page.

Mechanical Specs.

	744	844	948	1054	1252
Max Service Flow (gpm)	10	12	16	20	30
Dry Weight (lbs)	22	25	29	35	43
Service Weight (lbs)	80	97	129	168	235

Dimensions (nominal - inches)

a	48.5	48.5	52.5	59.5	56.5
b	46	46	48	57	54
c	7	8	9	10	12
d	2.5	2.5	2.5	2.5	2.5
e	3.0	3.0	3.0	3.0	3.0

Using ScaleStop with other water treatment equipment.

Due to the unique properties of ScaleStop, there are some unique requirements for using ScaleStop in conjunction with filtration or other forms of water treatment.

1. ScaleStop must be the last stage in the treatment chain. Do not install any filters after ScaleStop or before any devices for which scale prevention is required. POU filters, e.g. carbon or RO are exempt from this requirement.
2. Do not apply phosphate or any other antiscalant either before or after ScaleStop.

**An important note about iron, manganese and copper in the water supply.****Iron and Manganese**

Just as with conventional water softening media, ScaleStop needs to be protected from excess levels of certain metals that can easily coat the active surface, reducing its effectiveness over time. Public water supplies rarely, if ever, present a problem, but if the water supply is from a private well confirm that the levels of iron (Fe) and manganese (Mn) are less than 0.3 mg/L and 0.05 mg/L respectively. Copper should be less than 1.3 mg/L.

Copper

Copper usually originates from new copper plumbing upstream of the ScaleStop system. If this condition exists, we recommend waiting 3-4 weeks before placing the system in operation. This will allow the copper surfaces to be fully flushed and develop a natural protective surface. To further minimize any problem with excess copper the plumbers should be advised to avoid applying excess flux on the inner surfaces of the pipe and to use a low-corrosivity water soluble flux listed under the ASTM B813 standard. Once the plumbing connections are complete, place the ScaleStop system in bypass prior to following the startup procedure and flush the plumbing for at least 10 minutes.

**Cautions!**

- Do not let the system freeze. Damage to the tank may result.
- System must be operated in a vertical position. Do not lay it down during operation. The system may be placed in any position for shipping and installation but must be operated in the vertical position.
- Place the system on a smooth, level surface. Because the system operates in an UP-Flow, fluidized bed mode, having a level surface is more important than with a softener or media filter.
- A bypass valve should be installed on every system to facilitate installation and service.
- Observe all local plumbing and building codes when installing the system.

**Notes to the Installer.**

The ScaleStop system differs from a conventional softener or media filter in a number of key respects.

- The system is light and only partially filled with media. This is normal. The UP-flow operation of the system requires a lot of freeboard to allow the bed to fully fluidize.
- The system has no underbed so you can tip the system over without any fear of upsetting the media. This makes transportation and installation much easier than conventional systems.
- Because the ScaleStop system operates in the UP-Flow mode, the tank connections are opposite of what you're used to.
- Please see the "important note about iron, manganese and copper" above.
- Please see the note about "Using ScaleStop with other water treatment equipment" on the previous page.

Installation

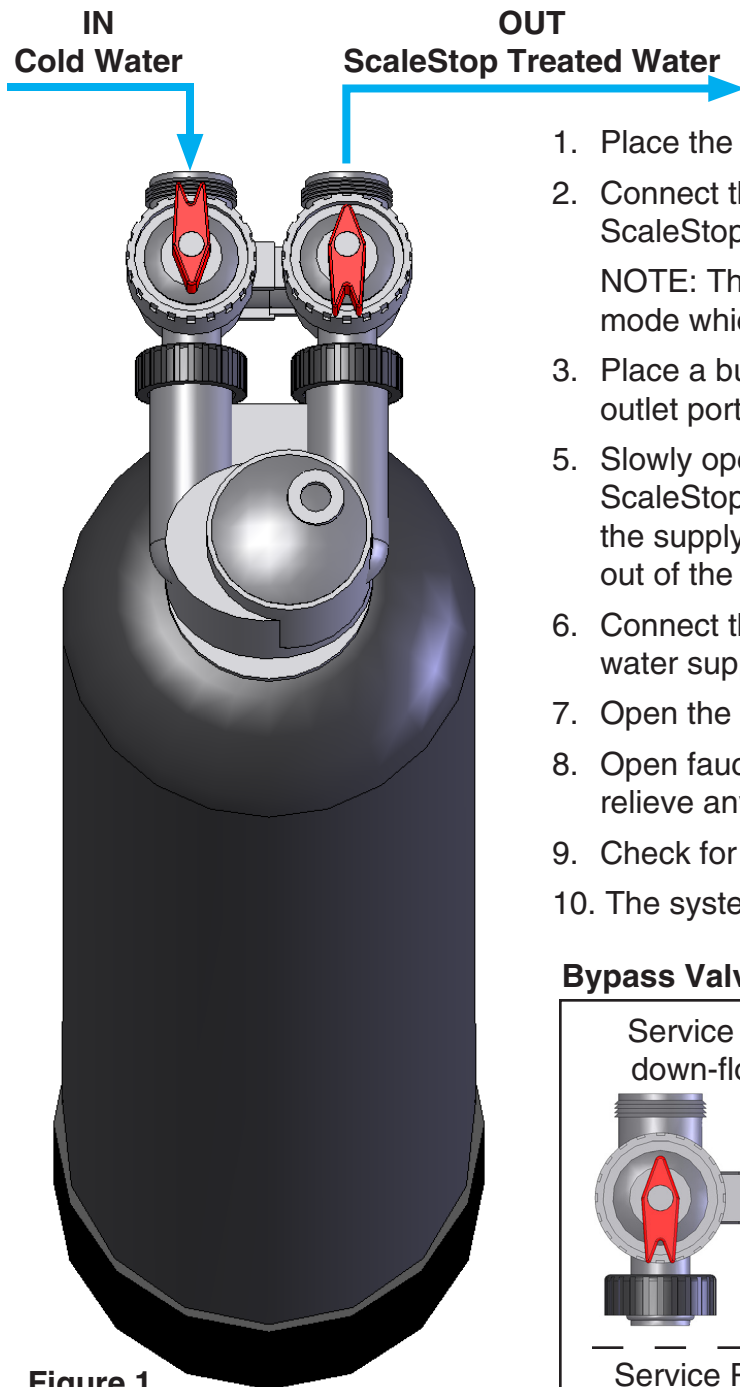
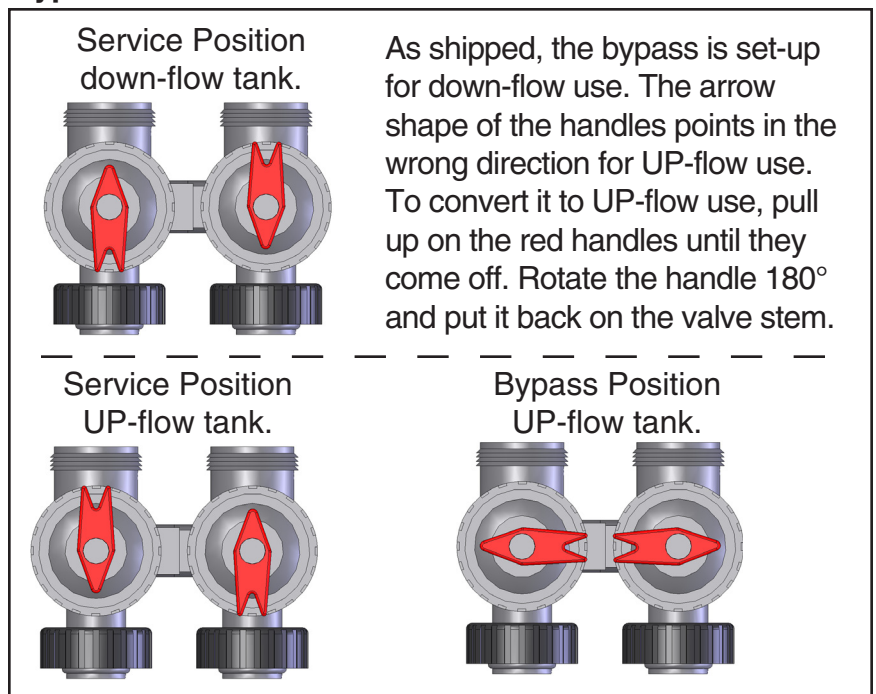

Figure 1.
844 shown with optional
bypass assy..

1. Place the system in the desired location.
2. Connect the Cold Water supply to the inlet of the ScaleStop system.

NOTE: The ScaleStop system operates in the UPFLOW mode which is opposite of a conventional softener.
3. Place a bucket under the outlet port or run a line from the outlet port to a drain.
5. Slowly open the supply valve (user supplied) to the ScaleStop system. Allow the tank to fill with water. Close the supply valve when a steady stream of water comes out of the outlet port.
6. Connect the Outlet of the ScaleStop system to the cold water supply to the home.
7. Open the supply valve to the ScaleStop system.
8. Open faucets downstream from the ScaleStop system to relieve any air.
9. Check for leaks. Repair as needed.
10. The system is now ready for service

Bypass Valve Modification



A note to the homeowner

Your ScaleStop system will improve the properties of water throughout your home. Here are some things to expect and some recommendations for maximizing the benefits and your enjoyment of ScaleStop



Sinks and fixtures - reduced spotting. If water is allowed to evaporate off a surface, small spots may be left behind. If wiped off frequently, the spotting should not require any more than a wet cloth or sponge to remove. No harsh chemical should be required as with typical hard water spotting.



Dishwasher-Spotting on dishes and on the surface of the dishwasher should be greatly reduced. We recommend that you immediately reduce the amount of dishwashing detergent by approximately 50% as compared to hard water use. Dishwashing detergents low in phosphates are highly recommended as they are better for the environment and phosphates can cause spotting. The use of a rinse aid may be advised.



Shower doors and tiles- should have reduced spotting. When water evaporates off a surface, small spots may be left behind. These spots should be easy to remove with a damp cloth or sponge. In very hard water areas treating the shower glass with Rain-X® 2 in 1 glass cleaner, or equivalent, will further reduce cleaning requirements.

In the bath you should notice that soaps and shampoos lather more than with un-treated water. Soaps and shampoos will also rinse off much easier and faster than they would with traditional soft water. We recommend the use of modern soaps for the best results.

Things to watch for:

During the first 30-90 days:

- Faucet aerators and drains may plug occasionally as old scale is removed from your plumbing system and water heater.
- You may also see milky water while the descaling is taking place. This is simply an increase in the calcium in the water because scaleStop is removing old scale deposits from your pipes.

Good practices:

If your dishwasher is severely coated with scale at the time of installation, we recommend that you purchase a product like Jet-Dry Dishwasher cleaner to accelerate the cleaning. After this initial cleaning ScaleStop should keep it clean.

We also recommend that you drain your water heater tank. This should be done 30 to 60 days after ScaleStop is installed, and again in one year. This is a good practice that can dramatically increase the life of your water heating appliance. If you have an electric "tank type" water heater, for optimum results and higher efficiency, we recommend you change the heating elements to a "low watt density" model. Please insure that the watt density is specified at less than 70 watts per square inch, and is compatible with the brand you own. If you can only change one heating element, change the lower unit which operates most of the time. One example is available at Home Depot (SKU # 258184). The ScaleStop will help keep the tank and heating elements free of scale and operating at peak efficiency. Please follow the manufacturer's instructions when draining or servicing the tank!

LIMITED WARRANTY

Next Filtration Technologies Inc. warrants the ScaleStop system as follows:

- The Tank is warranted to be free of defects in materials and workmanship for 10 years from the date of original installation.
- The Head is warranted to be free of defects in materials and workmanship for five years from date of original installation.
- The ScaleStop media is warranted for performance for a period of two years from the date of the original installation.

Conditions

1. The ScaleStop system must be installed and serviced by an authorized Next Filtration Technologies Inc. dealer, or other entity approved by Next.
2. Any component failure must not result from abuse, fire, freezing or other acts of nature, violence, or improper installation.
3. Equipment must be installed and operated in compliance with the local plumbing codes, and on an approved water supply.
4. Equipment is limited to use at water pressures not to exceed 100 PSI and temperatures not to exceed 110 degrees F.
5. Water supply must not exceed 3.0-PPM chlorine. For water supply exceeding 3.0 PPM chlorine, pretreatment is required. (Please contact your water treatment specialist.)
6. Information, including model number, serial number, and date of installation, must be provided for any claims pertaining to equipment in warranty.
7. Defective parts are subject to inspection by either Next Filtration Technologies, Inc. or any authorized representative before final commitment of warranty adjustment is made.
8. Next Filtration Technologies Inc. reserves the right to make changes or substitutions in parts or equipment with material of equal quality or value and of then current production.

Limitations

Our obligation under this warranty with respect to the tank or valve is limited to furnishing a replacement for, or at our option, repairing any part or parts to our satisfaction that prove defective within the warranty period stated above. Such replacement parts will be delivered to the owner F.O.B. nearest factory, at no cost, excluding freight and local labor charges, if any.

Our obligation under this warranty with respect to the Scale Stop media will be limited to furnishing a replacement for the media within two years from date of original installation. Such replacement media will be delivered to the owner F.O.B. nearest factory, at no cost, excluding freight and local labor charges, if any. Damage to the media due to chlorine, other oxidizers or fouling or any other operation outside of the limits shown under Specifications, is not covered by this warranty.

Next Filtration Technologies Inc. shall not be liable for freight, handling or labor charges, or consequential damages.

Warranty Registration

We appreciate your purchase of the chemical-free ScaleStop, scale control system. Under proper conditions you will have years of trouble-free performance from this product.

The laws of the United States do not require consumers to return warranty cards or registration cards to be covered by an implied warranty, however, you must keep a copy of your receipt.

At Next Filtration we support your rights as a consumer. We hope you will take the time to fill out the warranty registration below in order to insure that we have documentation showing that you have purchased the system and that a qualified technician installed it. The information provided will be kept in strict confidence and will never be available to marketing companies.

*** Please detach the section below, fill out the limited information and send it, along with a copy of your receipt to:

Next Filtration Technologies Inc
Warranty Registration
P.O. Box 4010
Incline Village, NV 89450

Owner's name:

Address: _____

Model number: _____

Installation date: _____

Installer or Dealer name: _____

Installer or Dealer contact number: _____

